

BIG KAISER

BIG A Member of the
BIG DAISHOWA Group

Fresatura Stampi di precisione

Lorenzo Canziani

Area Sales manager



BIG KAISER nella storia

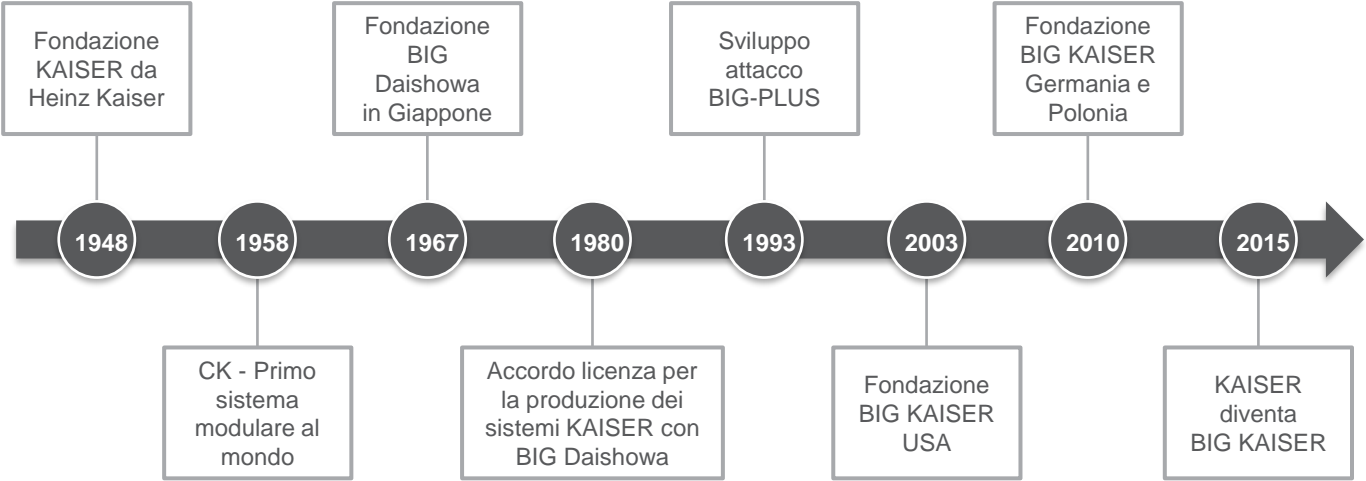



BIG KAISER in numeri



- Oltre **1000** dipendenti
- **9** stabilimenti produttivi
- Centro distribuzione di oltre **15'000m²/q**
- Oltre **100** brevetti
- Oltre **800** macchine utensili CNC
- Capacità produttiva di oltre 700.000 porta utensili/anno
- Area di Produzione coperta di oltre 200.000 m²/q
- 3 Tech Center (Giappone, Svizzera e USA)

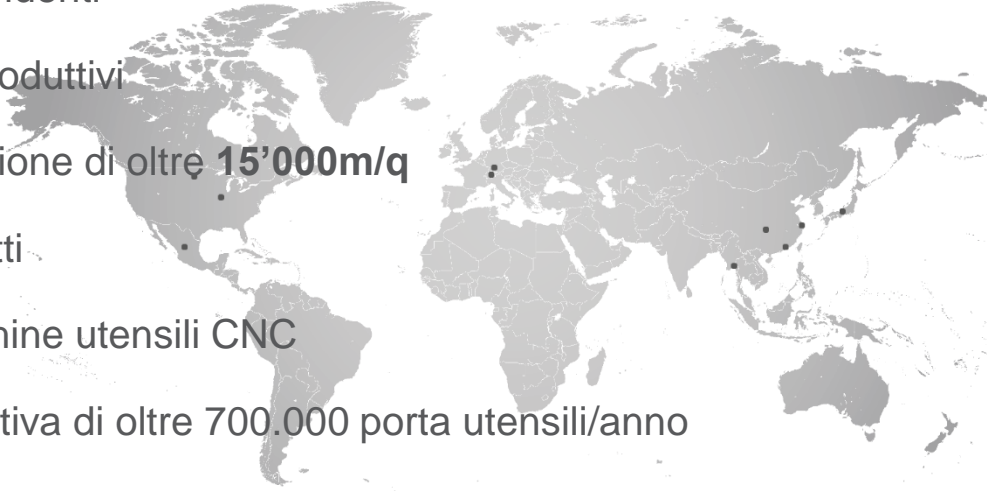

1. Rigidezza MEGA MICRO CHUCK

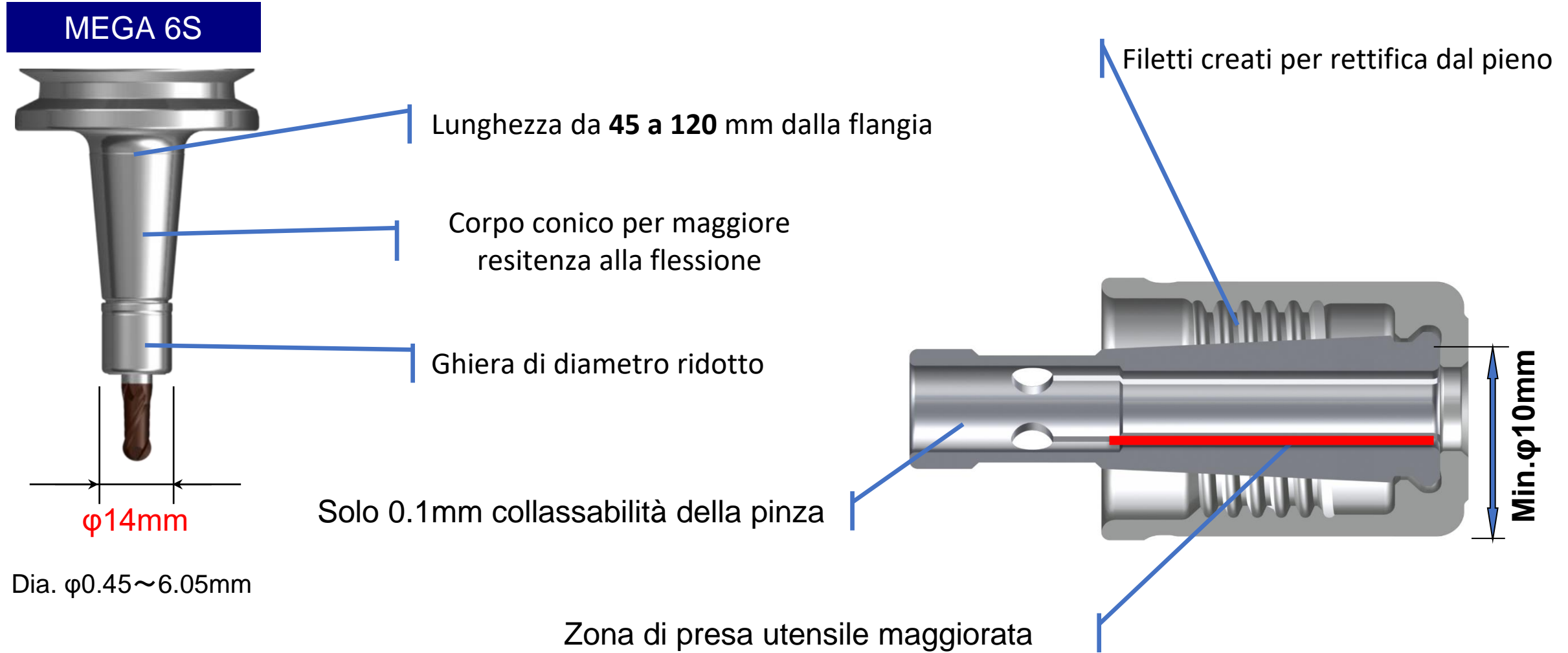

2. Precisione

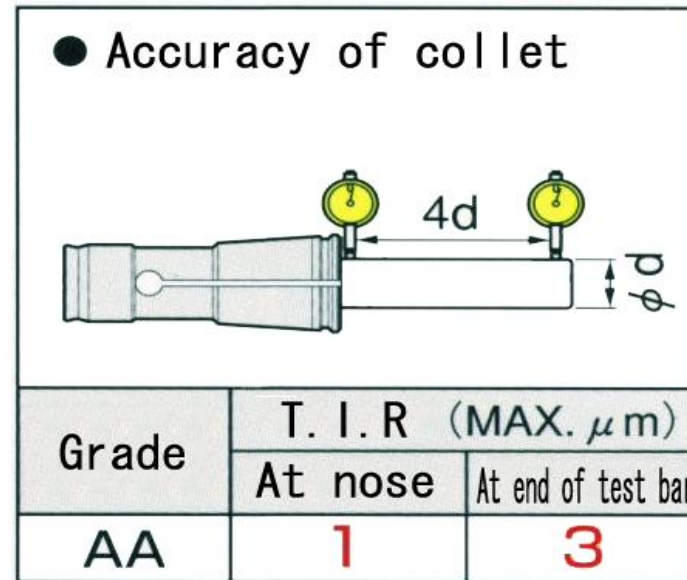

Codice univoco per ogni porta utensile



3. Garanzia di processo

Concentricità di una singola pinza provata 200 volte

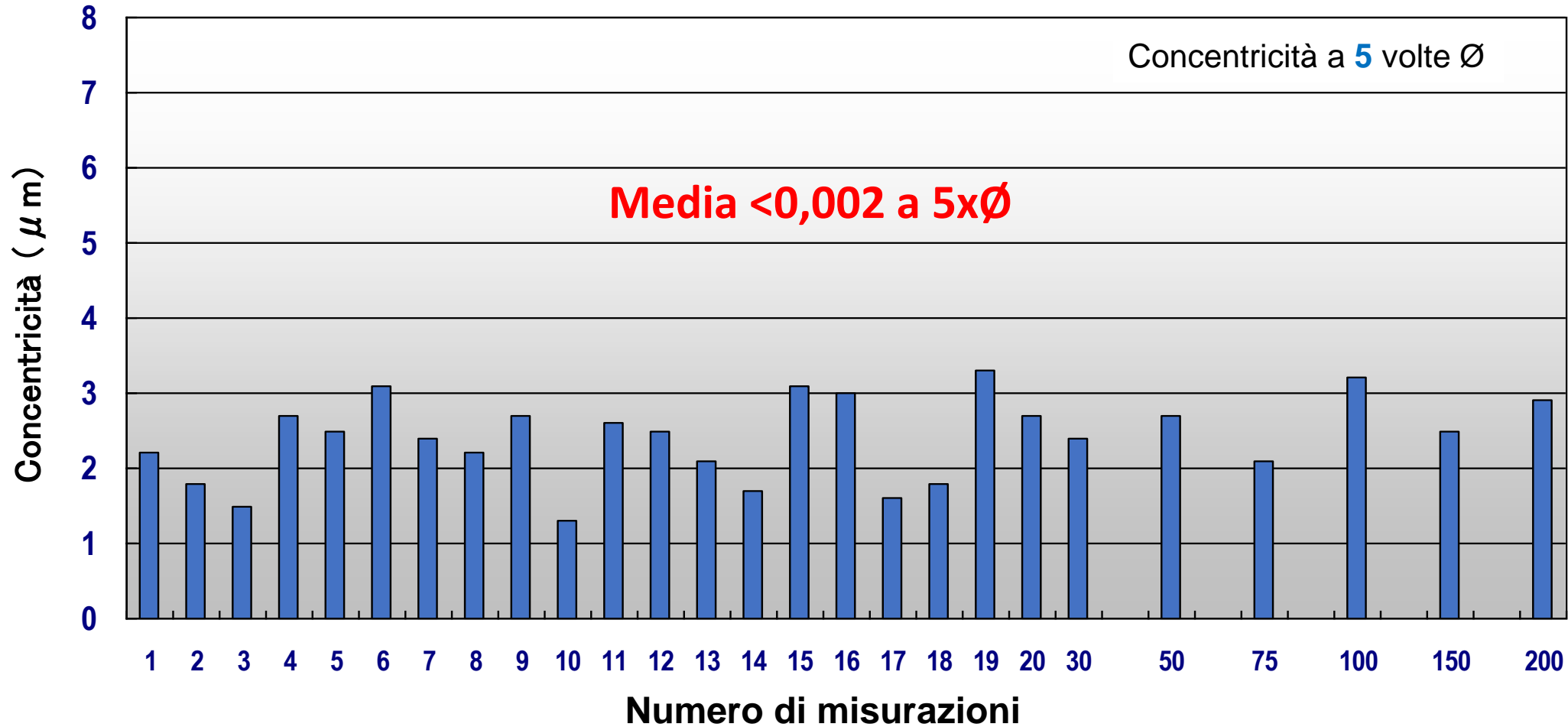

4. Evacuazione trucioli

Una cattiva gestione dell'evacuazione trucioli riduce fino al 60% la produttività e la qualità superficiale
Un truciolo rimasto nella zona di taglio puo' essere tagliato fino a 4 volte evitando di tagliare nuovo materiale

Ghiera MPS

2way coolant



Through tools with PS ring

Jet through without PS ring

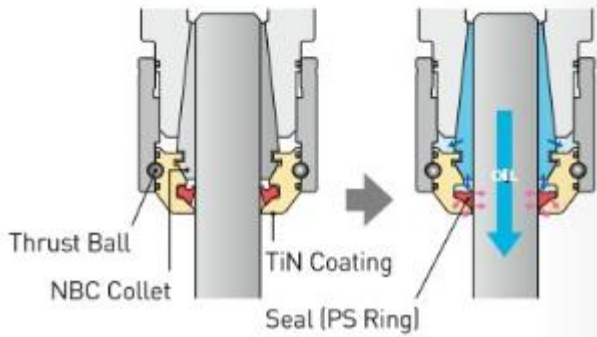

Ghiera MGN-S

For MEGA Micro Chuck
Sealed nut for coolant-through tools.

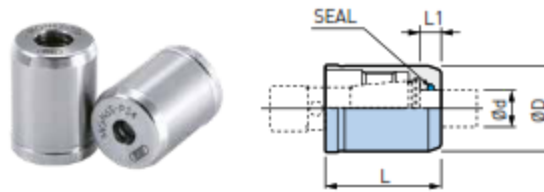

Idraulico lubrificazione centrale e periferica



Tip diameter
Min. Ø 20 mm
Max. 35.000min⁻¹

Ghiera MGN-J

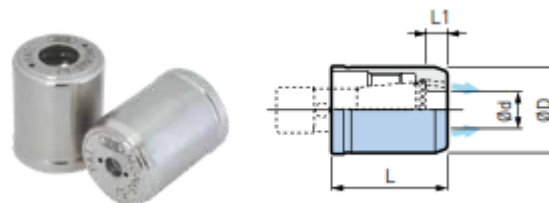

Idraulico lubrificazione periferica

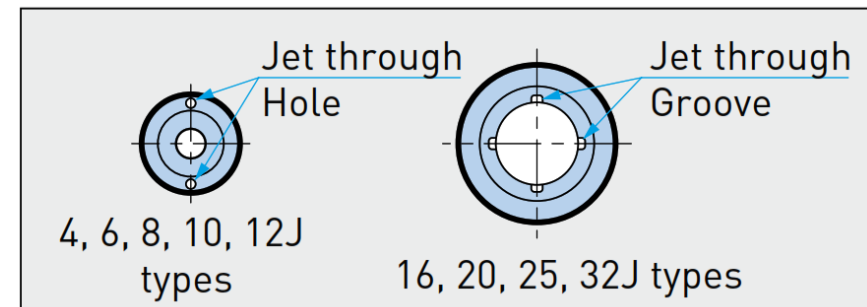

Io posso fare cose che tu non puoi fare, tu puoi fare cose che io non posso fare; insieme possiamo fare grandi cose.

Madre Teresa di Calcutta

BIG KAISER



A Member of the
BIG DAISHOWA Group

PARTNERSHIP

BIG KAISER